

Optimize High-Fidelity Readout with One Solution. Controlled.

Crescendo-S TWPA x SHFPPC

Josephson Travelling Wave Parametric Amplifiers (TWPAs) play a central role in reaching the highest qubit readout fidelities. By combining QuantWare’s Crescendo-S TWPA with the Zurich Instruments Quantum Computing Control System,

we demonstrate a highly integrated solution, ensuring high readout performance, a well-tested setup, as well as a fast and convenient tune-up procedure.

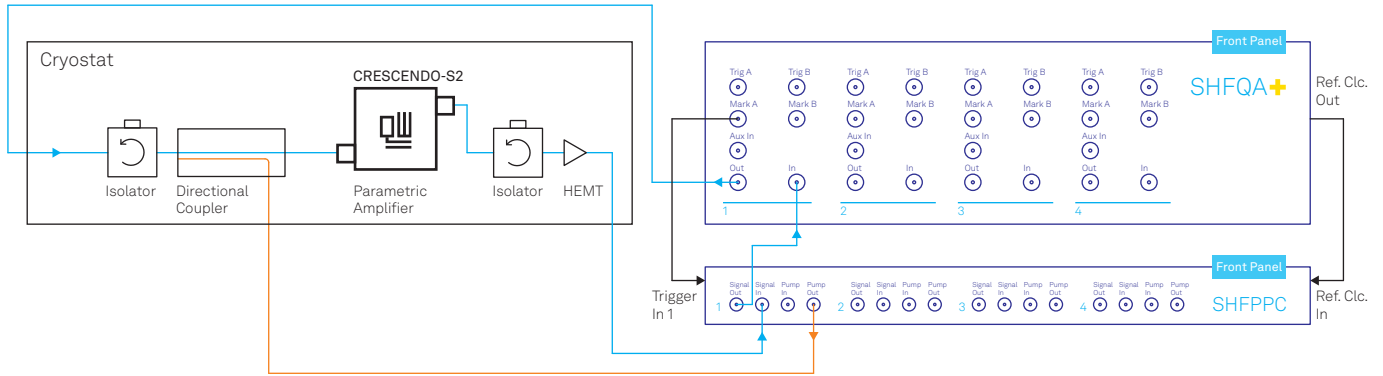

Figure 1. Typical setup diagram showing the SHFPPC Parametric Pump Controller and SHFQA+ Quantum Analyzer driving the Crescendo-S TWPA.

Your Benefits

- Optimal readout fidelities over more than 1 GHz readout bandwidth thanks to the high gain and low added noise of the Crescendo-S
- Flexibility and ease-of-use of Crescendo-S ensures a seamless interface to your setup
- Integrated solution with the SHFPPC for optimal operation of the Crescendo-S, enabling small setup overhead and fast amplifier tune-up
- Stable readout performance thanks to low drift, automated monitoring, and automated re-optimization within the LabOne Q software
- Accelerating quantum innovation through a joint offering to simplify the implementation of high-fidelity readout at scale

Your Application Resources

- Blog post: Crescendo-S TWPA x SHFPPC: Optimize High-Fidelity Readout with One Solution
- Blog post: TWPA tune-up with the SHFPPC
- Tune-up code example within the LabOne Q Applications Library

Discover more online



TWPA Tune-up Made Easy

- Dedicated tune-up routines and fast sweeping capabilities allow for up to twice-as-fast pump tone optimization compared to conventional control electronics (see figure 2)
- Excellent performance of the Crescendo-S2 within its large readout bandwidth (see figure 3)
- Up to 40dB suppression of the residual pump tone thanks to the SHFPPC’s built-in interferometric cancellation

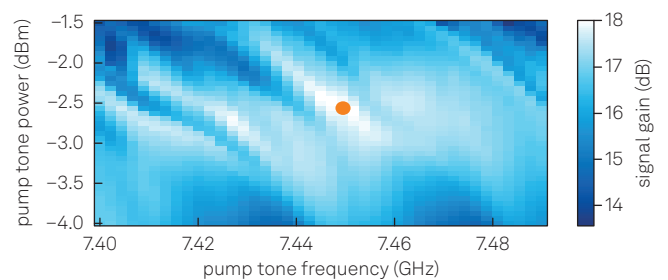

Figure 2. Signal gain as a function of pump tone power and pump tone frequency. The orange dot denotes the optimal pump tone settings.

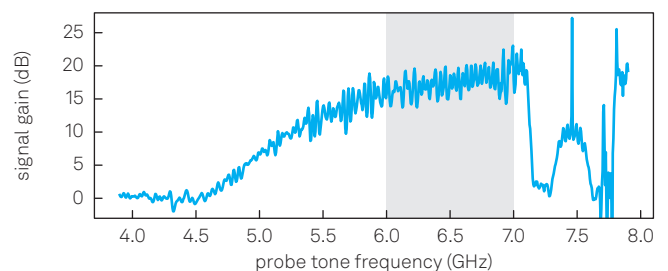
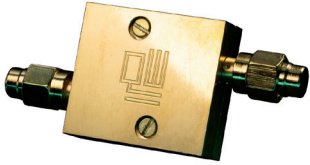

Figure 3. Signal gain as a function of probe tone frequency at the optimal pump tone setting.

Product Highlights



QuantWare Crescendo-S TWPA

Cutting-edge gain and noise performance over a wide readout band to enable highly multiplexed and cost-efficient readout. Designed to be flexible, scalable and easy to use, Crescendo-S is the readout amplifier for your application.



Zurich Instruments SHFPPC Parametric Pump Controller

Off-the-shelf solution for controlling Josephson parametric amplifiers. Ultra-stable pump tone signal generator with automatic leveling control.

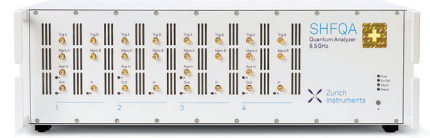

Zurich Instruments SHFQA+ Quantum Analyzer

Qubit, qutrit, or qudit readout in a frequency range up to 8.5 GHz without the need for mixer calibration.



All instruments are controlled by [LabOne Q](#), an open-source Python-based software framework offering both high- and low-level access. Achieve results quickly with extensive code examples, documentation, and support.

Meet Our Experts

Every member of our Quantum Technology team has a background in advanced scientific research, including quantum error correction, quantum sensing, quantum computing, and theory of quantum algorithms.



A Collaboration to Accelerate Quantum Innovation

QuantWare

Making Quantum Hardware Available to All

QuantWare is the world's leading quantum hardware manufacturer and specializes in QPU scaling technologies. QuantWare's VIO scaling architecture resolves current bottlenecks in scaling QPUs to unlock the fastest path towards utility-scale quantum processors.

Zurich Instruments

Your Readout. Controlled.

Zurich Instruments makes cutting-edge instrumentation for scientists and technologists who work in advanced laboratories and are passionate about phenomena often difficult to measure.